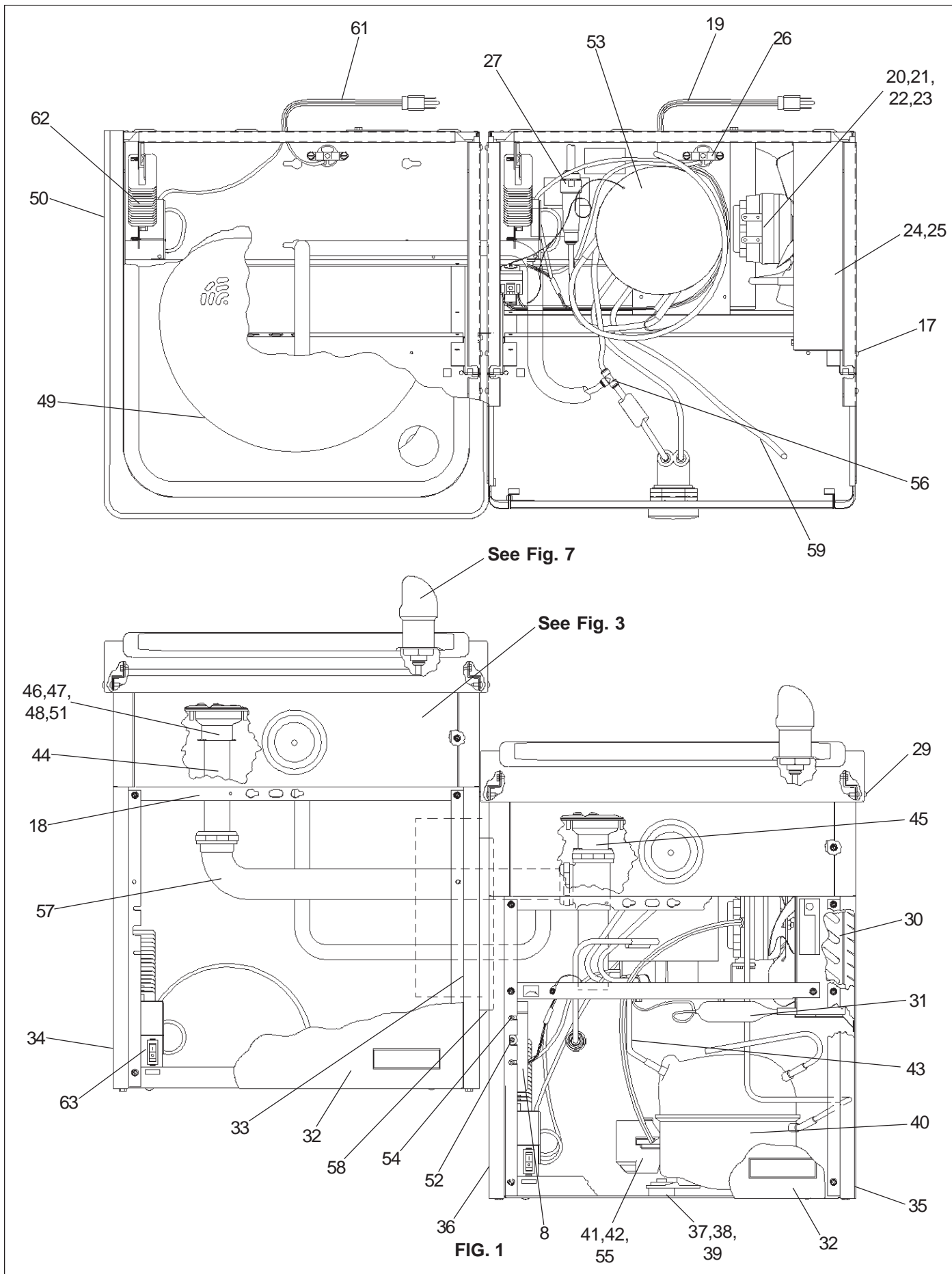


# Installation, Care & Use Manual

USES HFC-134A REFRIGERANT



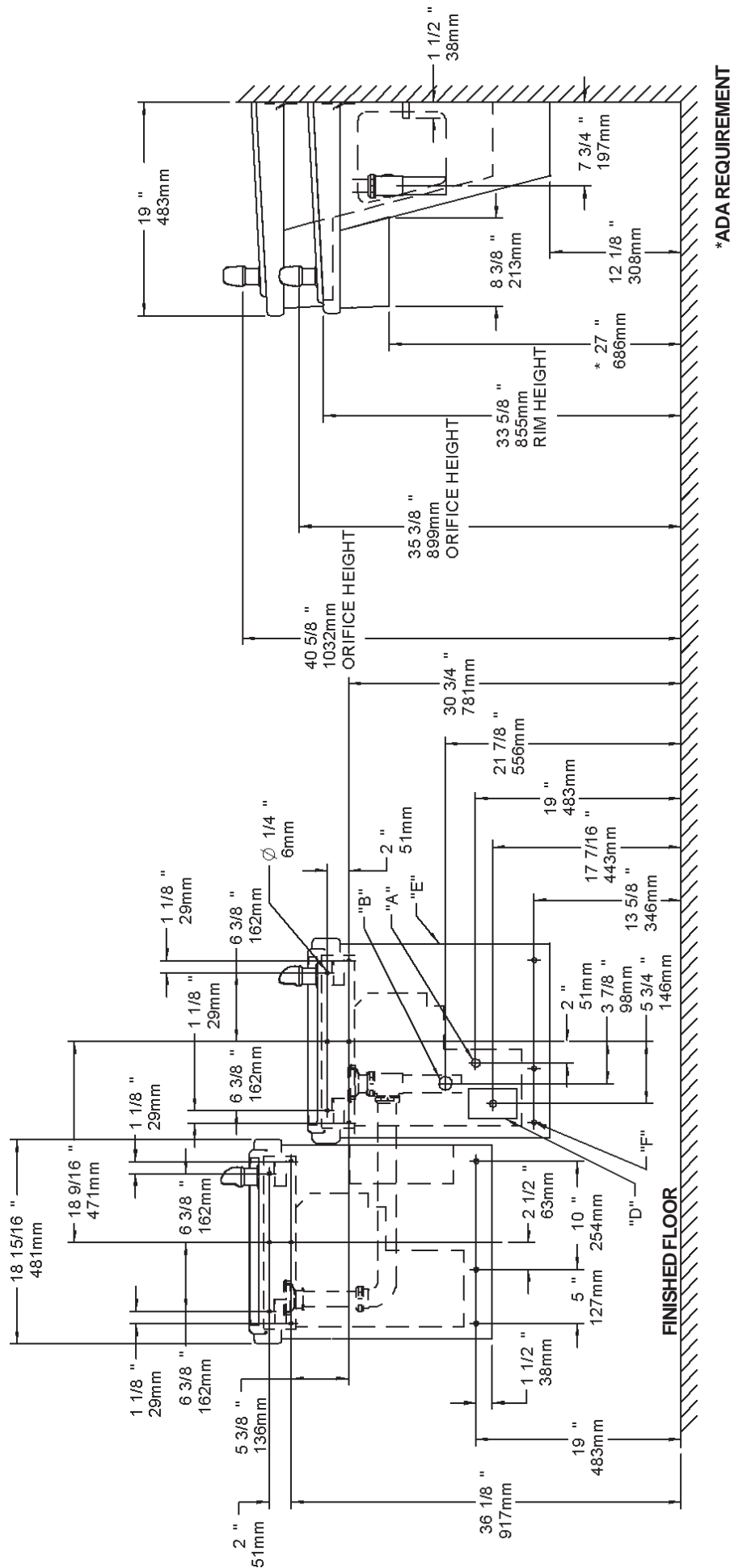


FIG. 2

**LEGEND**  
**A =** RECOMMENDED WATER SUPPLY LOCATION 3/8 O.D. UNPLATED COPPER TUBE  
**CONNECT STUB 1-1/2 IN. (38 mm) OUT FROM WALL SHUT OFF BY OTHERS**

**B =** RECOMMENDED LOCATION FOR WASTE OUTLET 1-1/2" O.D. DRAIN

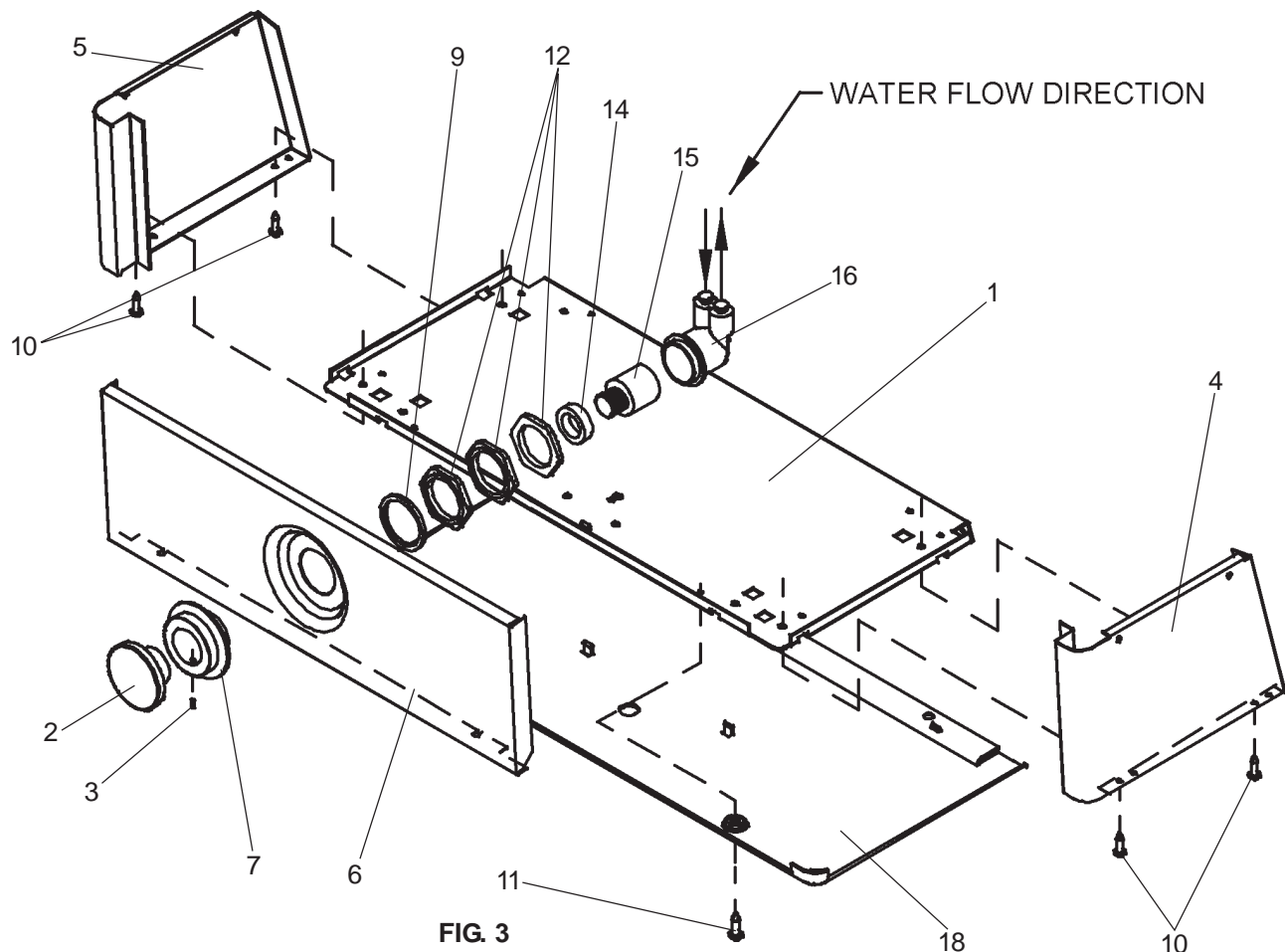
**C =** 1-1/2 TRAP NOT FURNISHED\*\*

**D =** ELECTRICAL SUPPLY (3) WIRE RECESSED BOX

**E =** INSURE PROPER VENTILATION BY MAINTAINING 6" (152 mm) (MIN.) CLEAR-  
**ANCE FROM CABINET LOUVERS TO WALL.**

**F =** 7/16 BOLT HOLES FOR FASTENING UNIT TO WALL

\*ADA REQUIREMENT



**IMPORTANT**  
**ALL SERVICE TO BE PERFORMED BY AN AUTHORIZED SERVICE PERSON**

**HANGER BRACKETS & TRAP INSTALLATION**

- 1) Remove hanger bracket fastened to back of cooler by removing one (1) screw.
- 2) Mount the hanger bracket and trap as shown in Figure 2.

**NOTE:** Hanger Bracket **MUST** be supported securely. Add fixture support carrier if wall will not provide adequate support.  
**IMPORTANT:**

- 7-3/4 in. (197mm) dimension from wall to centerline of trap must be maintained for proper fit.
  - Anchor hanger securely to wall using all six (6) 1/4 in. dia. mounting holes.
- 3) Install straight valve for 3/8" O.D. tube.

**INSTALLATION OF COOLER**

- 4) Hang the cooler on the hanger bracket. Be certain the hanger bracket is engaged properly in the slots on the cooler back as shown in Figure 2.
- 5) Loosen the two (2) screws holding the lower front panel at the bottom of cooler base and two (2) screws at the top. Remove the front panel and set aside.
- 6) Connect water inlet line--See Note 4 of General Instructions.
- 7) Remove the slip nut and gasket from the trap and install them on the cooler waste line making sure that the end of the waste line fits into the trap. Assemble the slip nut and gasket to the trap and tighten securely.

**START UP**

Also See General Instructions

- 8) Stream height is factory set at 35 PSI. If supply pressure varies greatly from this, adjust the screw on regulator item 15 by using a small screwdriver through the small hole in the push button item 2 (See Fig.3). CW adjustment will raise stream and CCW adjustment will lower stream. For best adjustment, stream should hit basin approximately 6-1/2" (165mm) from bubbler.

**PROTECT FROM HARD FREEZING**

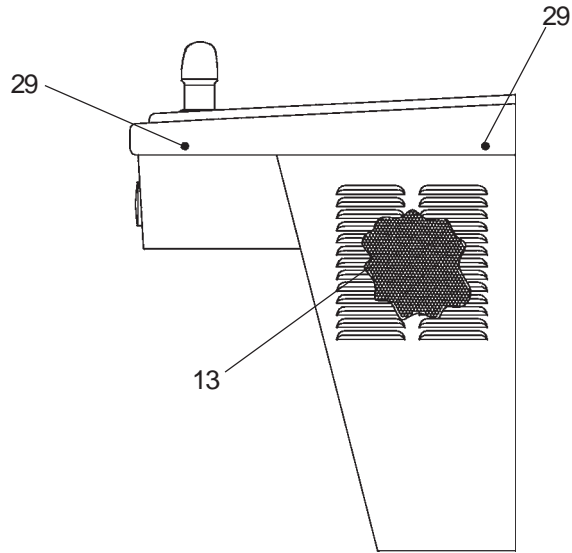
- 9) If the ambient air temperature drops below 0° F, the cooler needs to be drained of all water by blowing out all water lines, evaporator (item 53), and the drain trap.

ITEM NO.	PART NO.	DESCRIPTION
1	22897C	Panel-Bottom Dispenser
2	45662C	Button - Push
3	75672C	Screw - Cap
4	22822C	Panel-Right Side
5	22814C	Panel-Left Side
6	27295C	Panel-Front Push
7	45663C	Sleeve - Push Button
8	27124C	Cover - Cold Control
9	56033C	Washer
10	70864C	Screw-#8 x 5/8" Lg. Torx/Slot
11	75661C	Screw - Torx
12	40045C	Hex Nut
13	27469C	Panel - Screen
14	15005C	Retaining Nut
15	61313C	Regulator
16	50986C	Holder-Regulator
17	75532C	Screw-#10 x 1/2" Lg. THSM
18	55931C	Cover-Dispenser Bottom
19	35900C	Power Cord (Pressure Unit)
20	30664C	Fan Blade
21	70018C	Hex Nut - Fan Blade
22	31490C	Fan Motor 115V
23	70009C	Screw - (Fan Motor)
24	22899C	Shroud - Fan
25	38417001	Screw - #8-18 x 3/8" Lg.
26	35909C	Heater Thermostat Assy
27	55996C	Strainer
28	98118C	Bubbler Assembly
29	75566C	Screw - Torx
30	62152C	Condenser
31	66202C	Drier
32	22955C	Panel - Front Lower
33	26776C	Panel - Right Rear (Left Unit)
34	22854C	Panel - Left Rear (Left Unit)
35	22862C	Panel - Right Rear (Right Unit)
36	26800C	Panel - Left Rear (Right Unit)
37	101516143550	Stud - Compressor Mtg.
38	100806740570	Grommet - Compressor Mtg.
39	19037000	Clip - Compressor Mtg.
*40	36094C	Compressor Serv. Pak EMI 70 HNR
41	35959C	Relay
42	35768C	Cover - Relay
43	66576C	Heat Exchanger
44	45332C	Drain Tube (Left Unit)
45	45331C	Drain Tube (Right Unit)
46	50400C	Gasket - Drain
47	50401C	Ring Support - Drain
48	70444C	Clamp - Drain Gasket
49	21903C	Basin - Stainless Steel
50	27306C	Adaptor - Basin
51	70016C	Hex Nut #10-32
52	31513C	Cold Control
53	66534C	Evaporator Assembly
54	111411443890	Screw - #10 x 1/2" Lg. HHSM
55	36158C	Overload
56	70682C	Tee - 1/4 x 1/4 x 1/4
57	45449C	Drain Tube Assembly
58	26847C	Drain Trim Strip
59	56092C	Tubing - Poly (Cut To Length)
60	15009C	Bubbler - Nipple
61	36012C	Power Cord (Non-pressure Unit)
62	35906C	Heater Strip
63	35907C	Rocker Switch
64	100322740560	Gasket
NS	400660943730	Hanger Bracket (Not Shown)

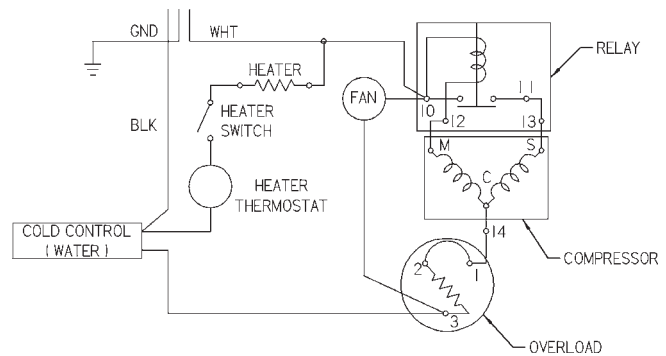
**WARNING!**

This unit is frost resistant down to 0° F with no wind. Prevailing winds can reduce the ability of the heater element to prevent light freezing. If the ambient air temperature will drop below 0° F, the cooler needs to be drained of all water by blowing out all water lines, evaporator (item 53), and the drain trap. A heater strip is used to heat the unit and will begin to cycle at 40° +/- 5° F. A check at this temperature will ensure the heater is working and the unit is resistant to light freezing.

**ALSO, MAKE SURE THERE ARE NO PLASTIC OR FLAMMABLE COMPONENTS DIRECTLY ABOVE THE HEATER STRIP.**

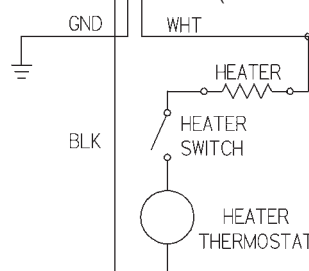


**FIG. 4**



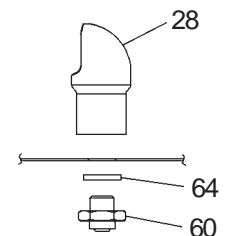
**FIG. 5**

(with Compressor)



**FIG. 6**

(without Compressor)



**FIG. 7**

\*REPLACE WITH SAME COMPRESSOR USED IN ORIGINAL ASSEMBLY.  
**NOTE:** All correspondence pertaining to any of the above water coolers or orders for repair parts MUST include Model No. and Serial No. of cooler, name and part number of replacement part

REPAIR SERVICE INFORMATION TOLL FREE NUMBER 1-800-260-6640

FOR PARTS, CONTACT YOUR LOCAL DISTRIBUTOR OR CALL 1.800.323.0620

ELKAY MANUFACTURING COMPANY • 2222 CAMDEN COURT • OAK BROOK, IL 60523 • 630.574.8484