

NOTICE: This water cooler must be connected to the water supply using a dielectric coupling.

INSTALLATION

- 1. This unit is intended for remote installation only.** It is important to insure proper ventilation. A minimum of 6 inches (152mm) to the front must be maintained, and 6 inches (152mm) to the rear of the unit.
- 2. This chiller has been designed for use with potable water** and includes an o-ring seal on the drain plug. This fitting should be replaced if the unit is to be used with more aggressive fluids.
- 3. Installer to provide air gap** at condenser water outlet to comply with local plumbing specifications.
- 4. Connecting lines to be made of copper.** Thoroughly flush all lines to remove all foreign matter before connecting to cooler. If flushing does not remove all particles, a water strainer should be installed in the supply line.
- 5. Connect cooler to building supply** with a shut-off valve and install a union connection between the valve and the cooler.
- 6. Electrical: Make sure power supply is identical** in voltage, cycle, and phase to that specified on cooler serial plate. Never wire the compressor directly to the power supply.

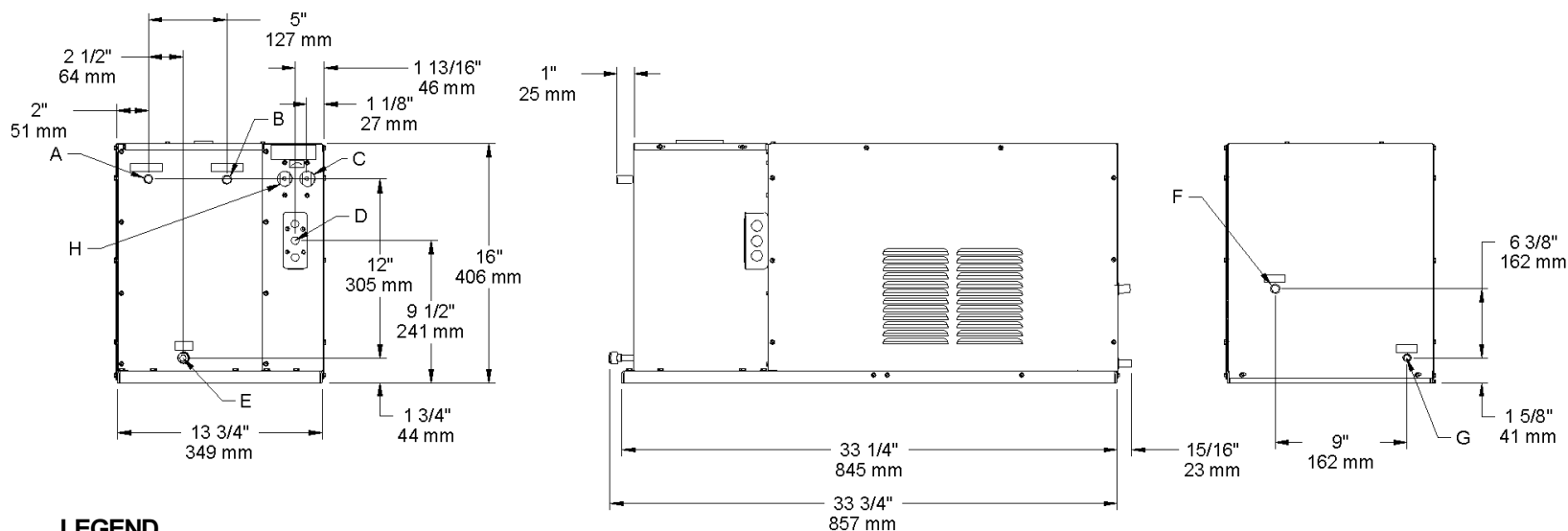

LEGEND

- A = 3/8" O.D. TUBE WATER INLET
- B = 3/8" O.D. TUBE WATER OUT
- C = TEMPERATURE ADJUSTMENT
- D = ELECTRICAL
- E = 3/8" O.D. TUBE TANK DRAIN
- F = 3/8" O.D. TUBE CONDENSER WATER OUTLET
- G = 3/8" O.D. TUBE CONDENSER WATER INLET
- H = FREEZE CONTROL

PARTS LIST		
ITEM NO.	PART NO.	DESCRIPTION
1	28165C	BOX - INSULATION
2	28218C	BASE ASSY
3	28166C	PANEL
4	28032C	PANEL - FRONT/REAR
5	23158C	COVER - INSULATION BOX
6	26701C	CABINET
7	34783005	WASHER - LOCK
8	35882C	CONTROL - COLD
9	66633C	CONDENSER ASSY
10	36034C	CSIR BOX ASSY
11	30768C	SOLENOID VALVE
*12	35985C	COMPRESSOR SERVICE PAK
13	35984C	OVERLOAD
14	35989C	GASKET - TERM COVER
15	35988C	OVERLOAD SPRING
16	35990C	BALE STRAP
18	50196C	GROMMET - COMPRESSOR MTG
19	66624C	EVAPORATOR ASSY
20	70772C	EVAPORATOR DRAIN PLUG
21	66621C	DRIER
22	70020C	NUT
23	30039C	ELECTRICAL BOX
24	66623C	HEAT EXCHANGER
25	30040C	ELECTRICAL BOX COVER
26	36045C	OVERLOAD COVER
27	70482C	MALE CONNECTOR FITTING
28	70274C	SLEEVE-COMPRESSOR
29	70483C	ELBOW FITTING
30	35895C	FREEZE CONTROL

START-UP

1. Open supply line valve.
2. Purge all air from all water lines by operating bubbler valve of fountain to which cooler is connected. A steady stream flow assures that all air is removed.
3. Rotate fan blade to assure proper clearance and free action.
4. Connect to proper electrical power.

IMPORTANT! INSTALLER PLEASE NOTE:

The grounding of electrical equipment such as telephone, computers, etc., to water lines is a common procedure. This grounding may be in the building, or may occur away from the building. This grounding can cause electrical feedback into a water chiller, creating an electrolysis which causes a metallic taste or an increase in the metal content of the water. This condition is avoidable by using the proper materials indicated below. Drain fittings which are provided by the installer should be plastic to electrically isolate the chiller from the building plumbing system.

TROUBLE SHOOTING & MAINTENANCE

- Temperature Control:** Factory set for 50°F water under normal conditions. To adjust water temperature, turn screw on Item No. 8 clockwise for colder, counter clockwise for warmer.
- Ventilation:** Cabinet louvers and condenser fins should be periodically cleaned with a brush, air hose, or vacuum cleaner. Excess dirt or poor ventilation can cause no cold water and compressor cycling on the overload protector.
- Lubrication:** Motors are lifetime lubricated.
- Actuation of Quick Connect Water Fittings:** Cooler is provided with lead-free plug which utilizes an o-ring seal. To remove plug from cooler, relieve water pressure, pull the collar towards the fitting and pull the fitting off the tube. To install plug, push fitting straight onto tubing until it reaches a positive stop, approximately 3/4".

*INCLUDES COMPRESSOR, CSIR BOX ASSY & OVERLOAD. IF UNDER WARRANTY REPLACE WITH SAME COMPRESSOR USED IN ORIGINAL ASSEMBLY.

NOTE: ALL CORRESPONDENCE PERTAINING TO ANY OF THE ABOVE WATER COOLERS OR ORDERS FOR REPAIR PARTS MUST INCLUDE MODEL NO. AND SERIAL NO. OF COOLER, NAME AND PART NO. OF REPLACEMENT PART.

NOTE: FOR USE WITH PHOTO PROCESSING APPLICATIONS, ADJUST THERMOSTAT TO WARMER SETTINGS.

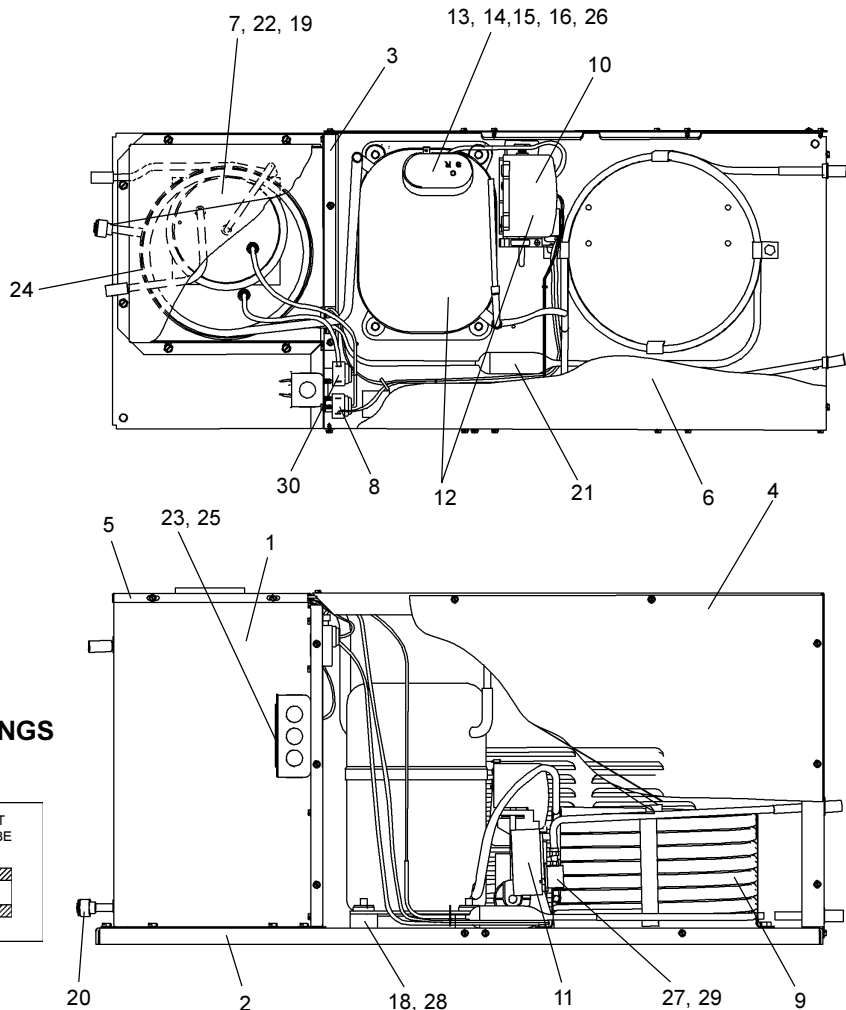
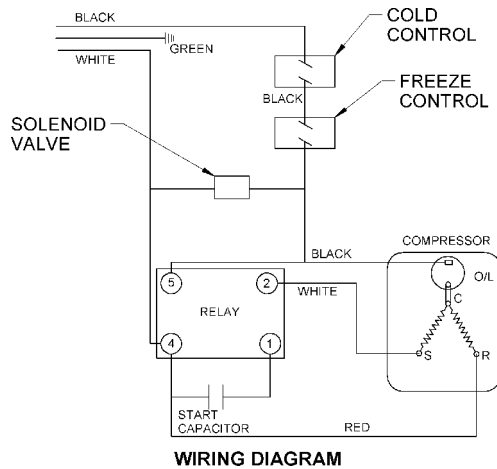

OPERATION OF QUICK CONNECT FITTINGS

