

# Installation/Care/Use Manual

EDFP110FPC EDFP114FPC EDFP117FPC  
Swirlflo® Freeze Resistant Fountains

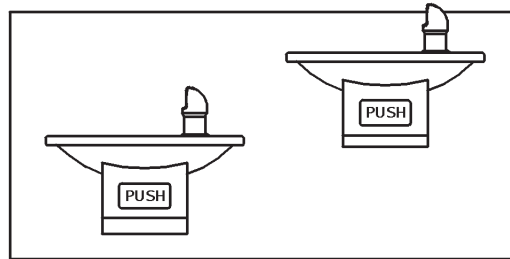
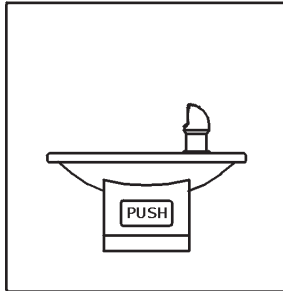

## Installer

To assure you install this model easily and correctly, PLEASE READ THESE SIMPLE INSTRUCTIONS BEFORE STARTING THE INSTALLATION. CHECK YOUR INSTALLATION FOR COMPLIANCE WITH PLUMBING, ELECTRICAL AND OTHER APPLICABLE CODES. After installation, leave these instructions inside the fountain for future reference. This Freeze Resistant Fountain is shipped in two separate cartons. The second carton contains the Freeze Resistant Package **LK616A** that is installed on an interior heated wall. Refer to the Freeze Resistant Package for the rough-in dimensions for installation.

## IMPORTANT

ALL SERVICE TO BE PERFORMED BY AN AUTHORIZED SERVICE PERSON

### IMPORTANT! INSTALLER PLEASE NOTE.

THE GROUNDING OF ELECTRICAL EQUIPMENT SUCH AS TELEPHONE, COMPUTERS, ETC. TO WATER LINES IS A COMMON PROCEDURE. THIS GROUNDING MAY BE IN THE BUILDING OR MAY OCCUR AWAY FROM THE BUILDING. THIS GROUNDING CAN CAUSE ELECTRICAL FEEDBACK INTO A FOUNTAIN, CREATING AN ELECTROLYSIS WHICH CAUSES A METALLIC TASTE OR AN INCREASE IN THE METAL CONTENT OF THE WATER. THIS CONDITION IS AVOIDABLE BY USING THE PROPER MATERIALS AS INDICATED. ANY DRAIN FITTINGS PROVIDED BY THE INSTALLER SHOULD BE MADE OF PLASTIC TO ELECTRICALLY ISOLATE THE FOUNTAIN FROM THE BUILDING PLUMBING SYSTEM.

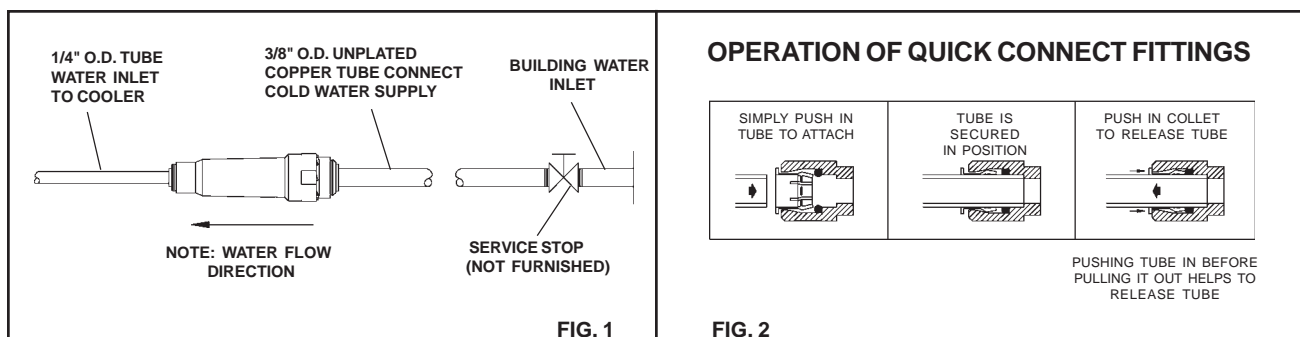



# EDFP110/114FPC ROUGH-IN

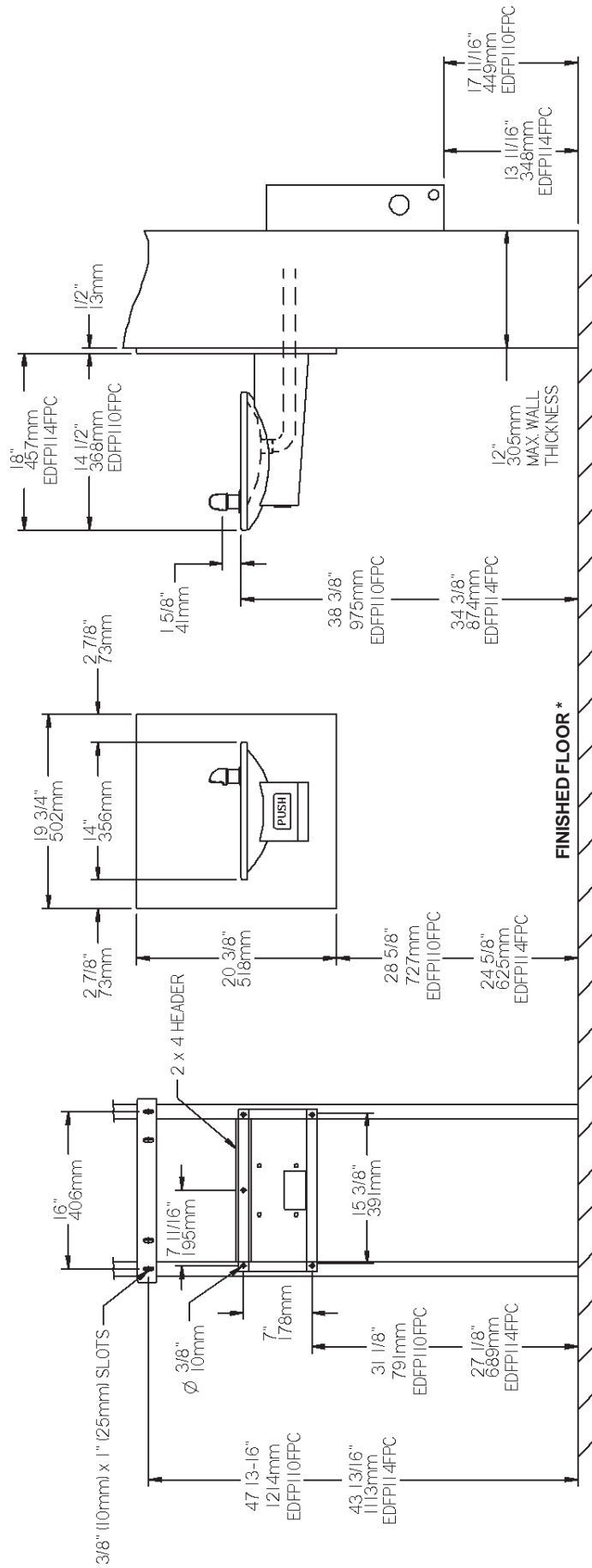

FIG. 4

\*NOTE: All dimensions are taken from the finished floor on the side of the wall that the fountain is installed on.

EDFP110/114/117FPC

PARTS LIST		
ITEM NO.	PART NO.	DESCRIPTION
1	21705C	CLIP-PUSHROD
2	28322C	BRACKET-PUSH BAR MTG.
3	21810C	PUSH BAR ASSY
4A	21822C	FTN BODY&SHELL EDFP110C
4B	21823C	FTN BODY&SHELL EDFP114C
5A	21845C	COVER PLATE EDFP110C
5B	21846C	COVER PLATE EDFP114C
6A	27314C	PANEL-BACK EDFP117FPC
6B	27315C	PANEL-BACK EDFP110/114FPC
7	98118C	BUBBLER ASSEMBLY
8	100322740560	GASKET
9	15009C	NIPPLE ASSY
10	50198C	BUSHING-SNAP
11	55001026	BASIN
12	70002C	SCREW-#10 X .50 HHSM
13	70410C	ROD-PIVOT
14	70426C	SCREW #8-32 X .25 THMS
15	75555C	CLIP -.125 STUD LOCK
16	*75559C	PUSH ROD ASSY
17	75570C	SCREW # 10 X .50 PINNED TORX
NS	27089C	HANGER BRACKET EDFP110/114FPC
NS	55000792	HANGER BRACKET EDFP117FPC
NS	27259C	BRKT ASSY-PANEL MOUNTING
NS	75520C	BIT-PINNED TORX

\* PARTS ARE SUPPLIED WITH FREEZE RESISTANT BOX

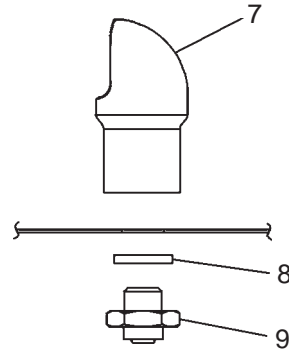

FIG. 5

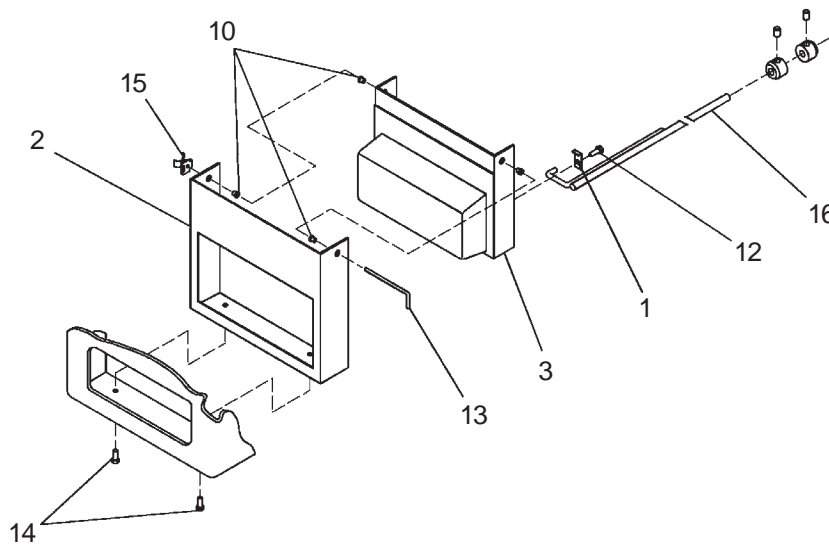
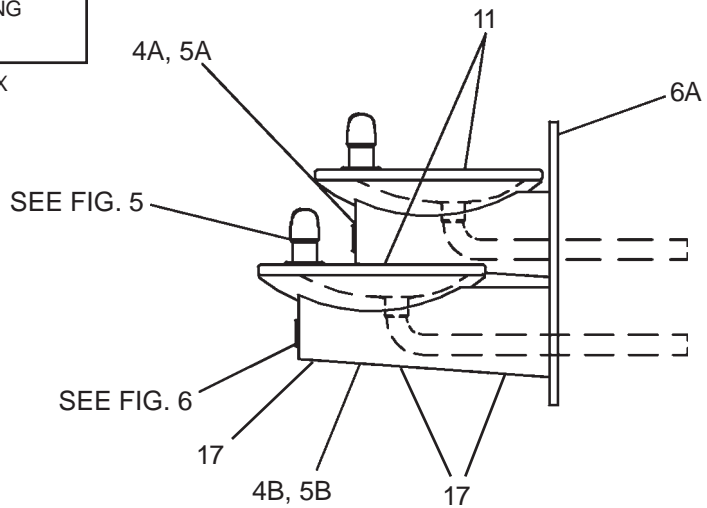

FIG. 6

FOR PARTS, CONTACT YOUR LOCAL DISTRIBUTOR OR CALL 1.800.323.0620  
 ELKAY MANUFACTURING COMPANY • 2222 CAMDEN COURT • OAK BROOK, IL 60523 • 630.574.8484