

# Installation / Care / Use Manual

## Refrigeration Package

### INSTALLATION

- 1. Insure proper ventilation.** In fully recessed drinking fountains be sure condenser faces louver panel and is within 1/2" (13 mm) of louver panel when panel is in place.
- 2. Water inlet is 3/8" (10 mm) O.D. unplated tube .** Contractor to supply connections as required.
- 3. Connecting lines to be made of unplated copper.** Thoroughly flush all lines to remove all foreign matter before connecting to cooler.
- 4. Connect cooler to building supply** with a shut-off valve and install a 3/8" (10 mm) unplated water line between the valve and cooler. Remove burrs from outside of water line. Insert water line into bulkhead union until it reaches a positive stop, approximately 3/4" (19 mm).

**NOTE: DO NOT SOLDER TUBES INSERTED INTO THE STRAINER AS DAMAGE TO THE O-RINGS MAY RESULT.**

- 5. Electrical: Make sure power supply is identical** in voltage, cycle, and phase to that specified on cooler serial plate. Never wire the compressor directly to the power supply.

### IMPORTANT! INSTALLER PLEASE NOTE:

The grounding of electrical equipment such as telephone, computers, etc., to water lines is a common procedure. This grounding may be in the building, or may occur away from the building. This grounding can cause electrical feedback into a water chiller, creating an electrolysis which causes a metallic taste or an increase in the metal content of the water. This condition is avoidable by using the proper materials indicated below. Drain fittings which are provided by the installer should be plastic to electrically isolate the chiller from the building plumbing system.

### START-UP

- 1. Open supply line valve.**
- 2. Purge all air from all water lines** by operating bubbler valve of fountain to which cooler is connected. A steady stream flow assures that all air is removed.
- 3. Rotate fan blade** to assure proper clearance and free action.
- 4. Connect to proper electrical power.**

### TROUBLE SHOOTING & MAINTENANCE

**Temperature Control:** Factory-set for 50°F water ( $\pm 5^\circ$ ) under normal conditions. For colder water, adjust screw on item no. 5.

**Ventilation:** Cabinet louvers and condenser fins should be periodically cleaned with a brush, air hose, or vacuum cleaner. Excess dirt or poor ventilation can cause no cold water and compressor cycling on the overload protector.

**Lubrication:** Motors are lifetime lubricated.

**Actuation of Quick Connect Water Fittings:** Cooler is provided with lead-free connectors which utilize an o-ring seal. To remove tubing from the fittings, relieve water pressure, push in on gray collar while pulling on the tubing. To insert tubing, push tube straight into fitting until it reaches a positive stop, approximately 3/4".

#### WIRING DIAGRAM

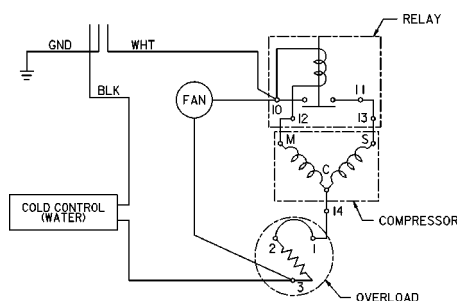

#### OPERATION OF QUICK CONNECT FITTINGS

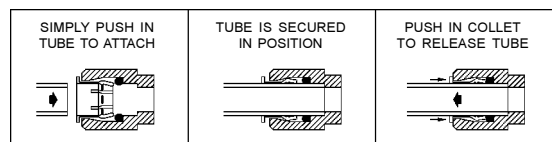

PUSHING TUBE IN BEFORE PULLING IT OUT HELPS TO RELEASE TUBE

## ECP8\*1C ECP8\*3C

PARTS LIST		
ITEM NO.	PART NO.	DESCRIPTION
1	66540C	EVAPORATOR ASSY
2	28339C	SHROUD - FAN
3	66531C	HEAT EXCHANGER
4	55996C	STRAINER
5	31513C	COLD CONTROL
6*	36094C	COMPRESSOR SERV. PAK
7	36158C	OVERLOAD
8	35768C	COVER RELAY
9	35959C	RELAY
10	19037000	CLIP - COMP MTG
11	101516143550	STUD - COMP MTG
12	100806740570	GROMMET - COMP MTG
13	20282C	BRACKET - FAN MTG
14	31490C	FAN MOTOR
15	70018C	NUT
16	30664C	FAN BLADE
17	66202C	DRIER
18	66305C	CONDENSER
19	31517C	POWER CORD

220V 60HZ		
ITEM NO.	PART NO.	DESCRIPTION
6*	36092C	COMP SERV. PAK
7	36174C	OVERLOAD
9	36050C	RELAY
14	31431C	FAN MOTOR
19	31506C	POWER CORD

**\*INCLUDES RELAY & OVERLOAD. IF UNDER WARRANTY REPLACE WITH SAME COMPRESSOR USED IN ORIGINAL ASSEMBLY.**

**NOTE: ALL CORRESPONDENCE PERTAINING TO ANY OF THE ABOVE WATER COOLERS OR ORDERS FOR REPAIR PARTS MUST INCLUDE MODEL NO. AND SERIAL NO. OF COOLER, NAME AND PART NO. OF REPLACEMENT PART.**

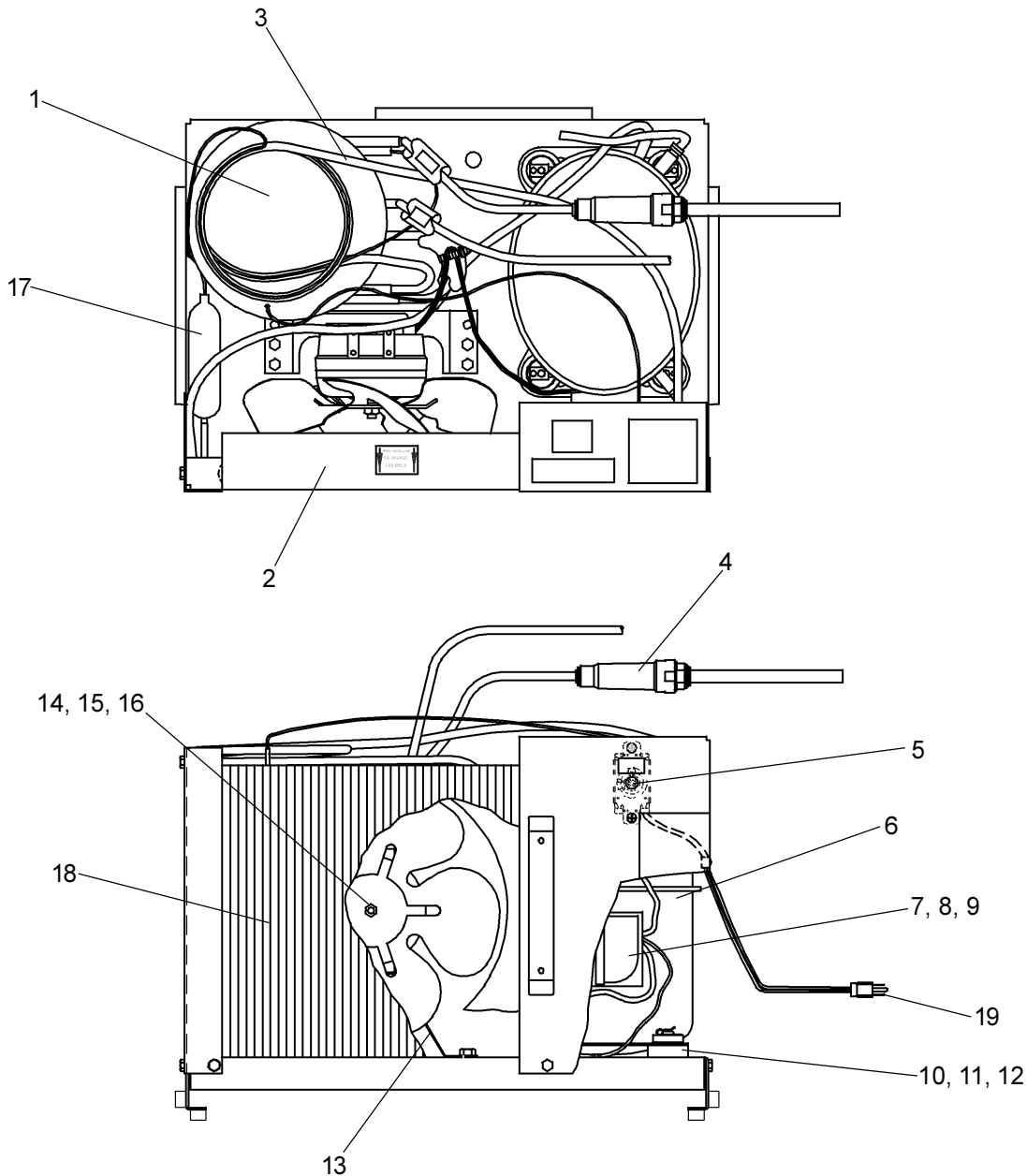

FOR PARTS, CONTACT YOUR LOCAL DISTRIBUTOR OR CALL 1.800.323.0620

ELKAY MANUFACTURING COMPANY • 2222 CAMDEN COURT • OAK BROOK, IL 60523 • 630.574.8484