

* REDUCE HEIGHT BY 3 INCHES FOR INSTALLATION OF CHILDRENS ADA COOLER.

FIG. 2

*ADA REQUIREMENT
*REQUISITO DE A.D.A.
*EXIGENCE ADA

LEGEND/LEVEIL/LEGENDE
A = RECOMMENDED WATER SUPPLY LOCATION 3/8 O.D. UNPLATED COPPER TUBE CONNECT STUB WITH SHUT OFF (BY OTHERS) 3 IN. (76mm) MAXIMUM OUT FROM WALL
 La UBICACION 3/8 O RECOMENDADA de ABASTECIMIENTO DE AGUA, D. EI TUBO del COBRE de UNPLATED CONECTA TALONARIO CON APAGO (POR OTROS) 3 en. (76 mm) el MAXIMO FUERA DE PARED
 L'O.D de 3/8 d'EMPLACEMENT DE PROVISION D'EAU RECOMMANDE. LE TUBE DE CUIVRE DE UNPLATED CONNCTE STUB AVEC ETEINT (PAR LES AUTRES) 3 dans. (76 mm) le MAXIMUM HORS DU MUR
B = RECOMMENDED LOCATION FOR WASTE OUTLET 1-1/2" O.D. DRAIN STUB 2 IN. OUT FROM WALL
 UBICACION RECOMENDADA PARA EL DRENAJE DE SALIDA DE AGUA, DE 1-1/2" DE DIAMETRO. EI TALONARIO 2 FUERA DE PARED
 EMBLACEMENT RECOMMANDE POUR LE DRAIN DE D.E. 1-1/2" DE SORTIE D'EAU. STUB 2 HORS DU MUR
C = 1-1/2 TRAP NOT FURNISHED*
 PURGADOR DE 1-1/2 NO PROPORCIONADO**
 SIPHON 1-1/2 NON FOURNI**

D = ELECTRICAL SUPPLY (3) WIRE RECESSED BOX
 CAJA RECESIVA DE ALAMBRES (3) DE SUMINISTRO ELECTRICO
 BOITE ENCASTRE D'ALIMENTATION ELECTRIQUE (3) FILS
E = INSURE PROPER VENTILATION BY MAINTAINING 6" (152 mm) (MIN.) CLEARANCE FROM CABINET LOUVERS TO WALL.
 ASEGURE UNA VENTILACION ADECUADA MANTENIENDO UN ESPACIO E 6" (152 mm) (MIN.) DE HOLGURA ENTRE LA REJILLA DE VENTILACION DEL MUEBLE Y LA PARED
 ASSUREZ-VOUS UNE BONNE VENTILATION EN GARDANT 6" (152 mm) (MIN.) ENTRE LES EVENTS DE L'ENCEINTE ET LE MUR.
F = 7/16 BOLT HOLES FOR FASTENING UNIT TO WALL
 AGUJEROS DE LAS TUERCAS DE 7/16 PARA SUJETAR LA UNIDAD A LA PARED
 TROUS D'ECROUS 7/16 POUR FIXER L'APPAREIL AU MUR

NOTE:
 ALL 4 OF THE 1/4" Ø HOLES AND BOTH OF THE 1/2" Ø HOLES SHOULD BE USED TO SECURE WALL BRACKET

HANGER BRACKETS & TRAP INSTALLATION

- 1) Remove hanger bracket fastened to back of cooler by removing one (1) screw.
 - 2) Mount the hanger bracket as shown in Figure 2.
- NOTE:** Hanger Bracket MUST be supported securely. Add fixture support carrier if wall will not provide adequate support. Anchor hanger securely to wall using all six (6) 1/4 in. dia. mounting holes.

IMPORTANT:

- 5-7/8 in. (150mm) dimension from wall to centerline of trap must be maintained for proper fit.

INSTALLATION OF COOLER

- 3) Hang the cooler on the hanger bracket. Be certain the hanger bracket is engaged properly in the slots on the cooler back as shown in Figure 2.
 - 4) Remove the six (6) screws holding the lower front panel at the bottom of cooler. Remove the front panel by pulling straight down and set aside.
 - 5) Connect water inlet line--See Note 4 of General Instructions.
 - 6) Install trap. Remove the slip nut and gasket from the trap and install them on the cooler waste line making sure that the end of the waste line fits into the trap. Assemble the slip nut and gasket to the trap and tighten securely.
- IMPORTANT:** If it is necessary to cut the drain, loosen the screw at the black rubber boot and remove tube, check for leaks after re-assembly.
- 7) Plug in electrical power.

START UP

Also See General Instructions

- 8) Stream height is factory set at 35 PSI. If supply pressure varies greatly from this, adjust screw located on the right knee clearance area. CW adjustment will raise stream and CCW adjustment will lower stream. For best adjustment, stream should hit basin approximately 6-1/2" (165mm) from bubbler on the downward slope of the basin.
- NOTE:** If continuous flow occurs at the end of the compressor cycle, turn cold control (Item 37) counterclockwise 1/4 turn.
- 9) Replace the front panel ensuring that the metal wrapper is secured inside of the upper shroud. Replace all six screws previously removed.

SENSOR RANGE ADJUSTMENT: The electronic sensor used in this cooler is factory pre-set for a "visual" range of 36 inches (914 mm). If actual range varies greatly from this or a different setting is desired, follow the range adjustment procedure below:

- A. Disassemble the unit.
- B. Using a small tip screwdriver, rotate range adjustment screw clockwise to increase range and counterclockwise to decrease range (See Fig. 4).

CAUTION: Complete range of sensor (24-28 inches/610-711mm) is only one turn of the adjusting screw.

- C. Re-assemble the unit.

SENSOR CONTROL: If sensor fails to operate valve mechanism or operates erratically, check the following.

- A. Ensure there are no obstructions within a 40 inch (1016mm) radius in front of cooler.
- B. Check wire connections at the solenoid valve and sensor. **CAUTION:** Make sure unit is unplugged before checking any wiring.
- C. Ensure proper operation of solenoid valve. If there is an audible clicking sound yet no water flows, look for an obstruction in the valve itself or elsewhere in the water supply line.

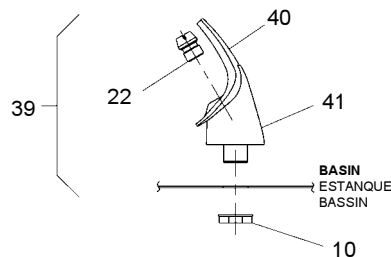

NOTE:
WHEN INSTALLING REPLACEMENT BUBBLER
AND PEDESTAL, TIGHTEN NUT (ITEM 10) ONLY
TO HOLD PARTS SNUG IN POSITION.
DO NOT OVER TIGHTEN.

FIG.3

PARTS LIST/ LISTA DE PIEZAS/ LISTE DES PIÈCES

ITEM NO	PART NO	DESCRIPTION
1	111411443890	Screw - #8-36 x .38 Tri-Lobed
2	56005C	Shroud - Upper
3	31516C	Sensor - Clear
	31384C	Sensor - Clear (Model EZODTL Only)
4	38417001	Screw - #10 x .37 PHTC
5	36004C	Wire - Jumper
6	56079C	Pushbar - Front
7	56074C	Pushbar - Side
8	56071C	Drain
9	50129C	Bumper - Press Bar
10	75580C	Nut - Lock 3/8 x 18
11	61314C	Regulator
12	50986C	Holder - Regulator
13	27846C	Shroud - Fan Top
14	27847C	Shroud - Fan Bottom
15	35978C	Power Cord
	31376C	Power Cord (Model EZODTL Only)
16	30664C	Fan Blade
17	70018C	Hex Nut - Fan Blade
18	31490C	Fan Motor
19	33133000	Adapt - Tab .250
20	75583C	Elbow - John Guest
21	27864C	Wrapper TL R - Light Gray
	27862C	Wrapper TL R - Stainless Steel
	27854C	Wrapper TL L - Light Gray
	27852C	Wrapper TL L - Stainless Steel
22	40322C	Orifice Assy
23	56092C	Poly Tubing (Cut to length)
24	35981C	Valve - Solenoid
25	62152C	Condenser
26	66202C	Drier
27	101516143550	Stud - Compressor Mtg.
28	100806740570	Grommet - Compressor Mtg.
29	19037000	Clip - Compressor Mtg.
30*	36086C	Compressor Serv. Pak EM170HER
31	36084C	Relay
32	35768C	Cover - Relay
33	66576C	Heat Exchanger
34	66575C	Drain Tube
35	75584C	Clamp - Drain
36	55001109	Basin - Stainless Steel
37	31513C	Cold Control
38	66534C	Evaporator Assembly
39	56073C	Bubbler Assy
40	56011C	Housing Assembly
41	55997C	Pedestal
42	36083C	Overload
43	27965C	Hanger Bracket
44	75532C	Screw - #10-16 x 63 THSM
45	56082C	Nut - Regulator
46	45463C	Waste Line Assy TL
47	66595C	Tube - Dummy to TL
48	66612C	Tube - Drain EZTL
49	70682C	Tee 1/4
NS	28020C	Wrapper - Filler (Not Shown)

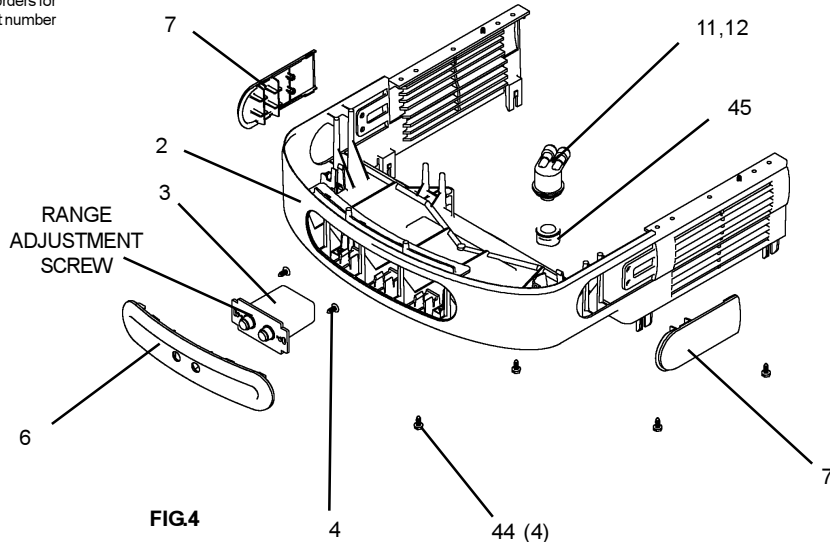
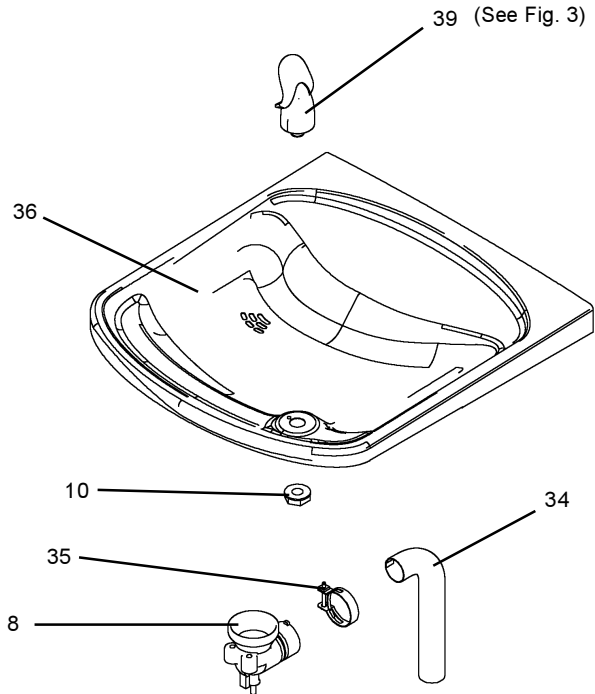
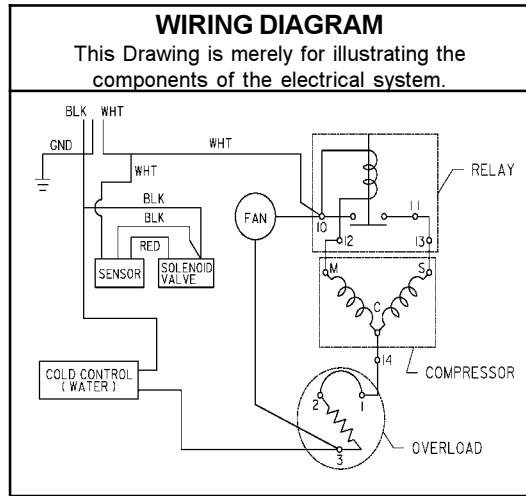

*REPLACE WITH SAME COMPRESSOR USED IN ORIGINAL ASSEMBLY.
 NOTE: All correspondence pertaining to any of the above water coolers or orders for repair parts MUST include Model No. and Serial No. of cooler, name and part number of replacement part.

FOR PARTS, CONTACT YOUR LOCAL DISTRIBUTOR OR CALL 1.800.323.0620

ELKAY MANUFACTURING COMPANY • 2222 CAMDEN COURT • OAK BROOK, IL 60523 • 630.574.8484