

INSTRUCTION SHEET - 97224C EHF(S)A VANDAL RESISTANT KIT

THIS KIT CONTAINS A SUFFICIENT QUANTITY OF TAMPER-RESISTANT SCREWS TO MODIFY YOUR WATER COOLER.

INSTRUCTIONS FOR MODIFICATIONS:

1. REMOVE EXTERIOR SCREWS ONE AT A TIME AND REPLACE WITH A TAMPER-RESISTANT SCREW OF THE SAME SIZE AND LENGTH. SPECIAL DRIVE BITS ARE PROVIDED FOR THE TAMPER-RESISTANT SCREWS.

CAUTION: DO NOT REMOVE ALL EXTERIOR SCREWS BEFORE REPLACING THEM WITH TAMPER-RESISTANT SCREWS.

2. KIT CONSISTS OF:

ITEM	QTY.	PART NO.	DESCRIPTION
1	1	75523C	BIT-PINNED TORX
2	1	75520C	BIT-PINNED TORX
3	10	75661C	SCREW - #8 X .50
4	15	75570C	SCREW - #10 X .50

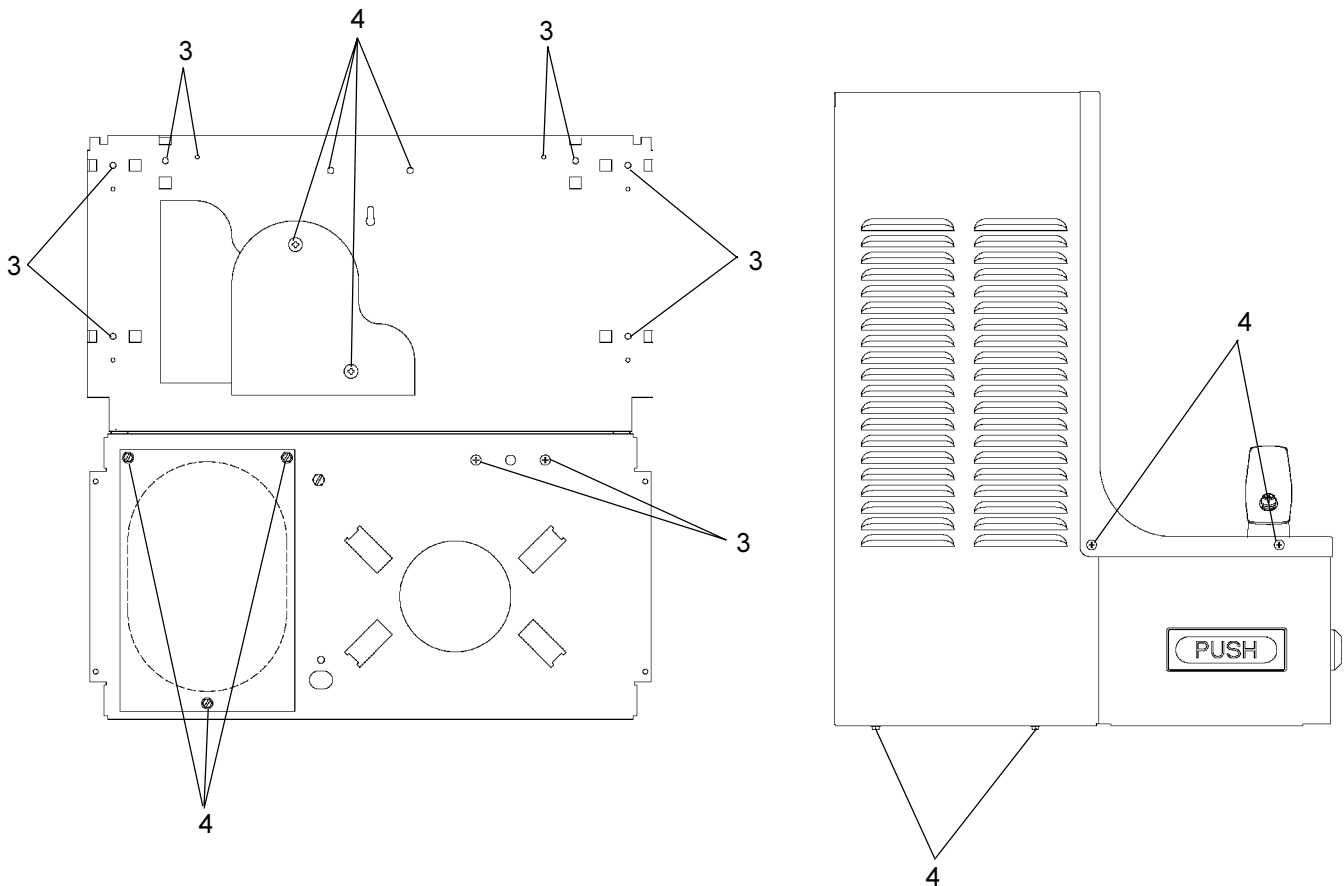

FOR PARTS, CONTACT YOUR LOCAL DISTRIBUTOR OR CALL 1.800.323.0620
ELKAY MANUFACTURING COMPANY • 2222 CAMDEN COURT • OAK BROOK, IL 60523 • 630.574.8484