

# Installation/Care/Use Manual

**EDFP10FPC EDFP14FPC EDFP17FPC**  
**Freeze Resistant Fountains**

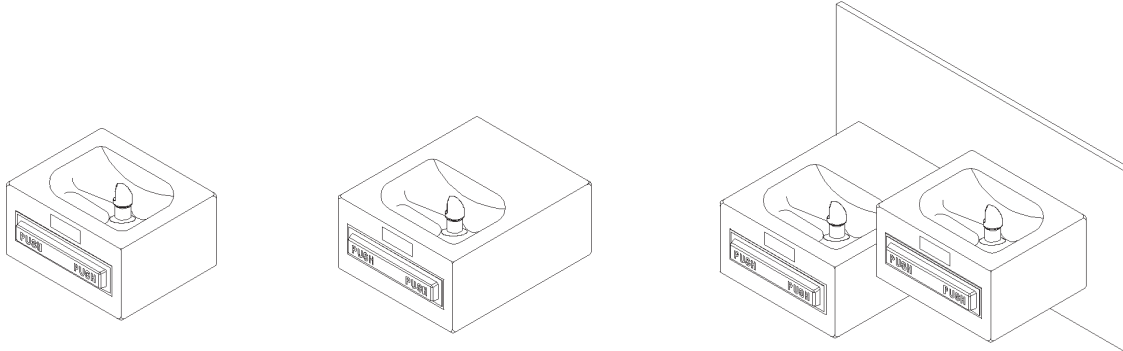

## Installer

To assure you install this model easily and correctly, PLEASE READ THESE SIMPLE INSTRUCTIONS BEFORE STARTING THE INSTALLATION. CHECK YOUR INSTALLATION FOR COMPLIANCE WITH PLUMBING, ELECTRICAL AND OTHER APPLICABLE CODES. After installation, leave these instructions inside the fountain for future reference. This Freeze Resistant Fountain is shipped in two separate cartons. The second carton contains the Freeze Resistant Package **LK616A** that is installed on an interior heated wall. Refer to the Freeze Resistant Package for the rough-in dimensions for installation.

## IMPORTANT

ALL SERVICE TO BE PERFORMED BY AN AUTHORIZED SERVICE PERSON

### IMPORTANT! INSTALLER PLEASE NOTE.

THE GROUNDING OF ELECTRICAL EQUIPMENT SUCH AS TELEPHONE, COMPUTERS, ETC. TO WATER LINES IS A COMMON PROCEDURE. THIS GROUNDING MAY BE IN THE BUILDING OR MAY OCCUR AWAY FROM THE BUILDING. THIS GROUNDING CAN CAUSE ELECTRICAL FEEDBACK INTO A FOUNTAIN, CREATING AN ELECTROLYSIS WHICH CAUSES A METALLIC TASTE OR AN INCREASE IN THE METAL CONTENT OF THE WATER. THIS CONDITION IS AVOIDABLE BY USING THE PROPER MATERIALS AS INDICATED. ANY DRAIN FITTINGS PROVIDED BY THE INSTALLER SHOULD BE MADE OF PLASTIC TO ELECTRICALLY ISOLATE THE FOUNTAIN FROM THE BUILDING PLUMBING SYSTEM.

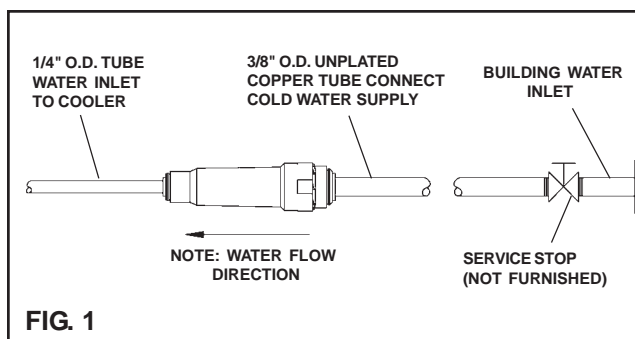

### OPERATION OF QUICK CONNECT FITTINGS

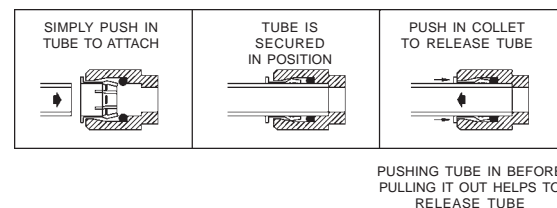

# EDFP17FPC ROUGH-IN

**LEGEND:**  
**A = 1/4 DIA. (6mm) HOLE**  
**B = 1/4 DIA. (6mm) SLOT**  
**C = 3/16 DIA. (5mm) HOLE**

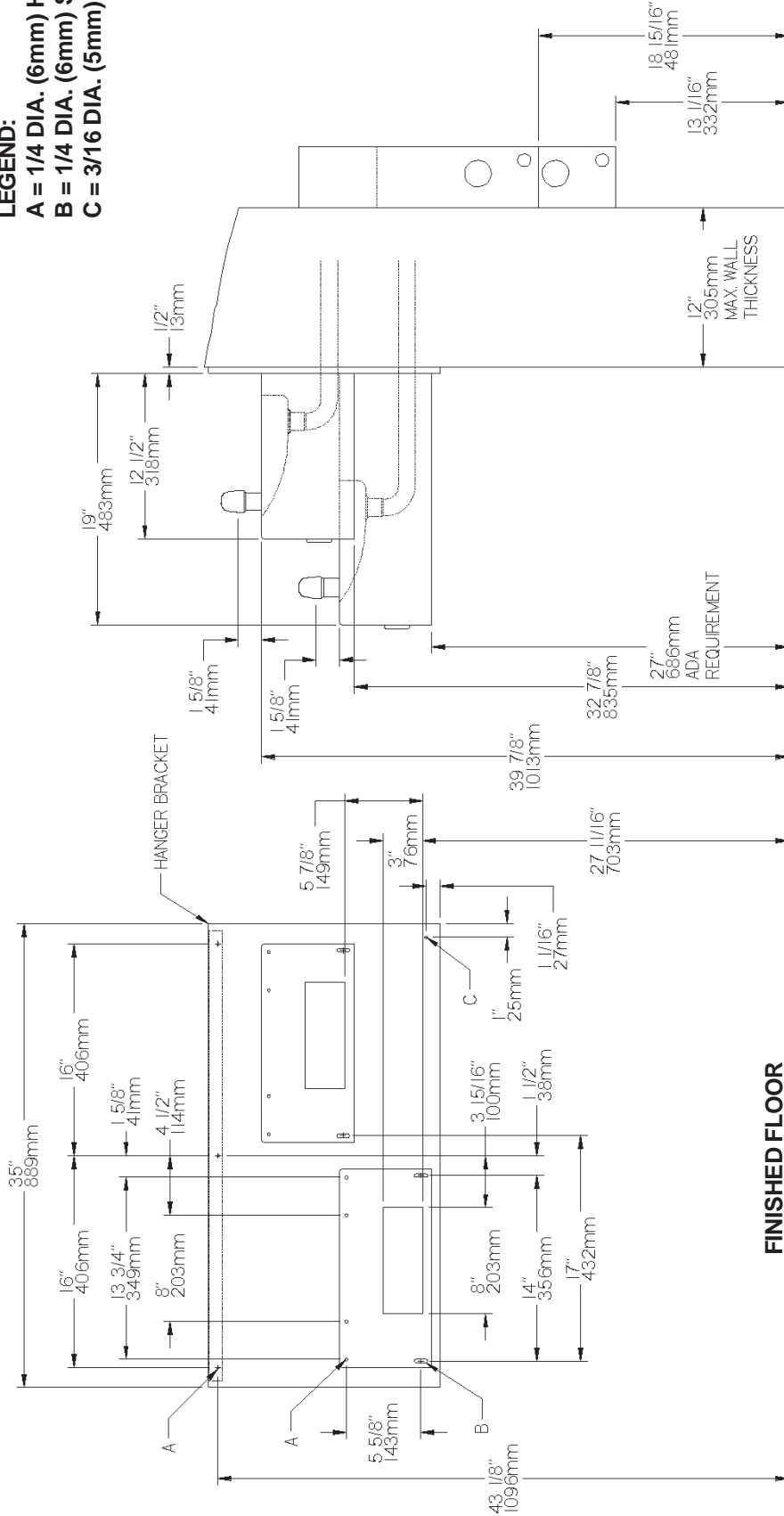

**FIG. 3**

- 1. Wall should already be framed for the fountain using dimensions shown in Fig. 3.** Show dimensions pertain to installation location. These dimensions are required for compliance with ANSI Standard A117.1. (and ADA) (Framing shown for reference only).
  - 2. Attach the hanger bracket and panel mounting bracket(s) to the wall as shown in Fig. 3.** Use bolts and flat washers (not provided). Tighten securely.
  - 3. Install the back panel.** Place the upper edge of the panel above the hanger on the wall. Slide the panel down until it engages the hanger. Be sure panel is firmly engaged before releasing it.
  - 4. Remove bottom cover(s) from fountain(s) and save the screws.** Assemble push rod(s) to fountain(s). See Fig. 6. (Push rods provided with freeze-resistant boxes)
  - 5. Install the fountain(s) to the wall.** Bolt through the fountain and through the back panel into the wall. (Bolts are not provided). **NOTE:** The back panel is "sandwiched" between the fountain and the wall. The back panel **DOES NOT** support the fountain. All support for the fountain must come from the mounting wall.
  - 6. Attach drain tube(s)** (supplied with freeze-resistant box) to fountain(s) and cut to required length using the freeze resistant box as a guide.
  - 7. Install freeze-resistant box** - see box instructions.
  - 8. Install a service stop (not provided)** and make water supply connection from the stop to the strainer(s) in the freeze-resistant box.
  - 9. Connect fountain water line to freeze-resistant box** - see box instructions. Replace bottom cover(s).
- \*NOTE: All dimensions are taken from the finished floor on the side of the wall that the fountain is installed on.**

# EDFP10/14FPC ROUGH-IN

**LEGEND:**

- A = 1/4 DIA. (6mm) HOLE
- B = 1/4 DIA. (6mm) SLOT
- C = 1-3/4" (44mm) HOLE FOR WASTE LINE
- D = 7/8" DIA. (22mm) HOLE FOR WATER INELT
- E = 1" DIA. (25mm) HOLE FOR PUSH ROD

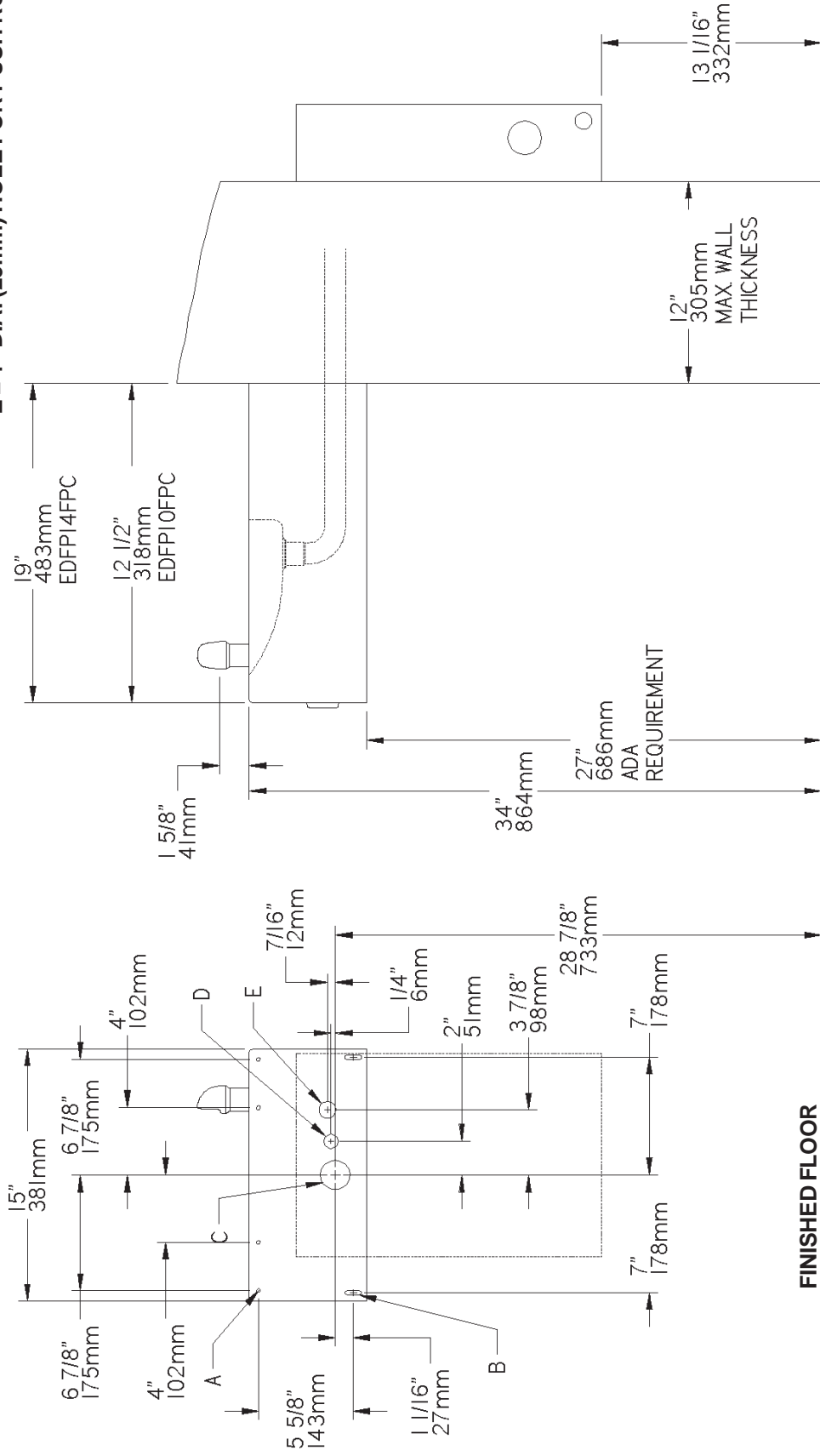

FIG. 4

\*NOTE: All dimensions are taken from the finished floor on the side of the wall that the fountain is installed on.

PARTS LIST		
ITEM NO.	PART NO.	DESCRIPTION
1	CP10	COVER PLATE
2	CP14	COVER PLATE
3	EDFPD10	FOUNTAIN BODY ASSEMBLY
4	EDFPD14	FOUNTAIN BODY ASSEMBLY
5	21696C	BRACKET-PUSH BAR MTG.
6	21705C	CLIP-PUSH ROD
7	21708C	PUSH BAR ASSY-BUFFED
8	98118C	BUBBLER ASSEMBLY
9	100322740560	GASKET
10	15009C	NIPPLE ASSY
11	50198C	BSHNG-SNAP .125ID
12	55001046	BACK PANEL ASSY.
13	70002C	SCREW-#10 X .50 HHSM
14	70278C	ROD-SUPPORT
15	75555C	CLIP-.125 STUD LOCK
*16	72000833	WASTE ARM ASSEMBLY

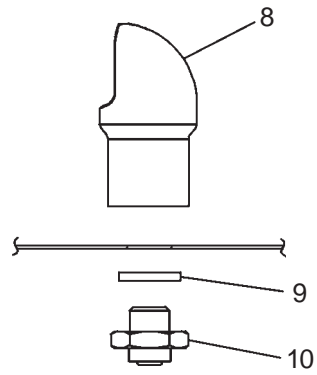

FIG. 5

\* PARTS ARE SUPPLIED WITH FREEZE RESISTANT BOX

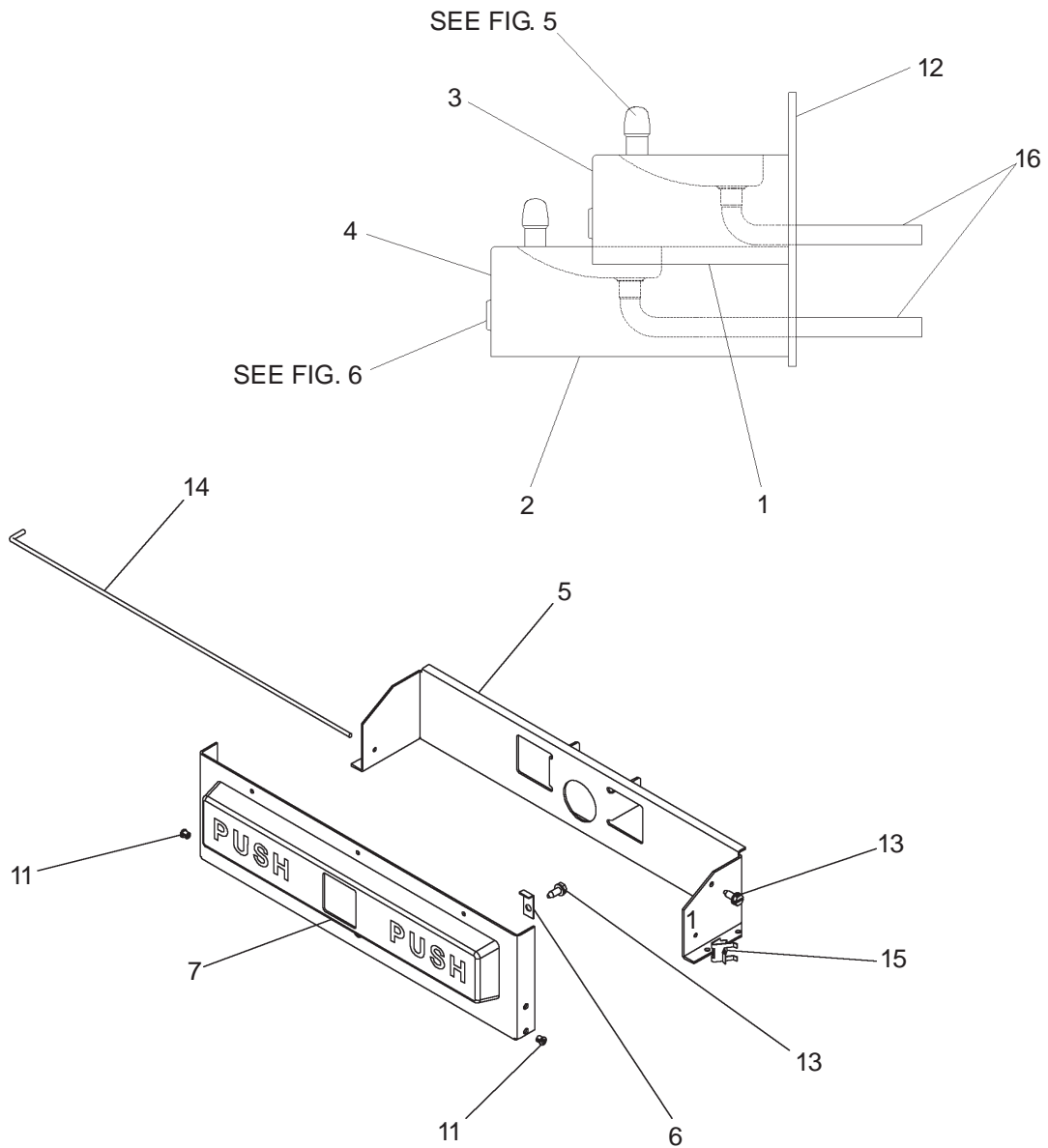

FIG. 6

FOR PARTS, CONTACT YOUR LOCAL DISTRIBUTOR OR CALL 1.800.323.0620  
 ELKAY MANUFACTURING COMPANY • 2222 CAMDEN COURT • OAK BROOK, IL 60523 • 630.574.8484