

# CP310 COVER PLATE

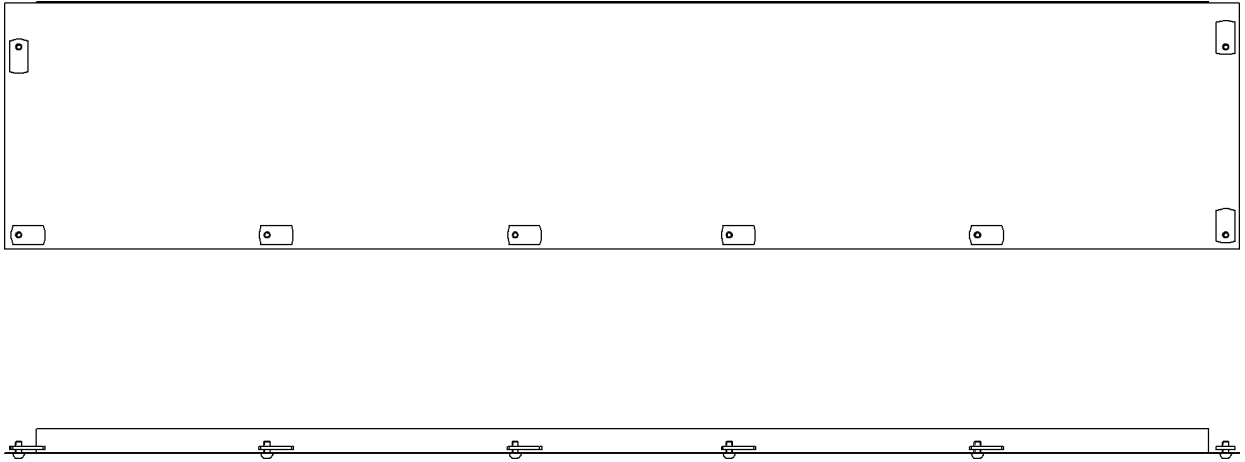

## HOW TO ATTACH COVER PLATE

### **STEP 1.**

POSITION WELD NUTS AND SCREWS AS SHOWN IN THE ABOVE PICTURE.

### **STEP 2.**

POSITION PLATE TO BOTTOM OF FOUNTAIN KEEPING EQUAL MARGIN ON EACH SIDE.

### **STEP 3.**

TIGHTEN SCREWS - AS SCREWS ARE DRAWN UP THE WING OF THE WELD NUT WILL SANDWICH THE FLANGE OF THE FOUNTAIN.

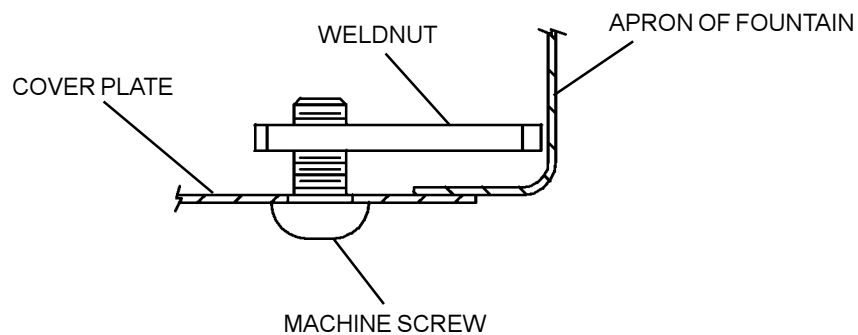

FOR PARTS, CONTACT YOUR LOCAL DISTRIBUTOR CALL 1.800.323.0620  
ELKAY MANUFACTURING COMPANY • 2222 CAMDEN COURT • OAK BROOK, IL 60523 • 630.574.8484