

RATED FOR INDOOR USE ONLY

PRODUCT SPECIFICATION

In-wall recessed bottle filling station for use with EDFPBM SwirlFlo[®] fountains station with high-efficiency ECH8GRN chilling unit. EZWSGRNM8PK shall deliver 8 GPH of 50° F drinking water at 90° F ambient and 80° F inlet water. Units shall be stainless steel construction with plastic ABS alcove. Sensor-activation with an auto 20-second shut-off timer. Shall include Green Ticker™ displaying count of plastic bottles saved from waste. Bottle filler shall provide 1.1 gpm flow rate with laminar flow to minimize splashing. Shall include integrated silver ion anti-microbial protection in key areas. Unit shall meet ADA guidelines. Unit shall be lead-free design which is certified to NSF/ANSI 61 and 372 and meets Federal and State low-lead requirements. Unit shall be certified to UL399 and CAN/CSA 22.2 No. 120.

STANDARD FEATURES

- High-efficiency ECH8GRN chilling unit
- Special panel height designed to pair with non-refrigerated EDFPBM SwirlFlo[®] models
- No-touch, sensor-activated operation
- Auto 20-second shut-off
- Integrated Silver Ion Anti-microbial Protection in key areas
- Quick Fill Rate: 1.1 gpm
- Laminar Flow provides minimal splash
- Real Drain System eliminates standing water
- Visual User Interface display includes:
 - Innovative Green Ticker™ counts bottles saved from waste.
- Includes lower hinged panel for easy access and servicing

COOLING SYSTEM

- High-efficiency compressor: hermetically-sealed, reciprocating type, single phase. Sealed-in lifetime lubrication.
- Condenser: Fan cooled. Fan motor is permanently lubricated.
- Cooling Unit: Combination tube-tank type. Continuous copper tubing with stainless steel tank. Fully insulated with EPS foam which meets UL requirements for self-extinguishing material.
- Refrigerant Control: Refrigerant R134a is controlled by accurately calibrated capillary tube.
- Temperature Control: Enclosed adjustable thermostat is factory preset. Requires no adjustment other than for altitude requirements, Easily accessible by removing lower grille panel.

CAPACITIES CHART

Model	Voltage / Hertz	Chilling** Capacity	F.L. Amps	Rated Watts	Approx. Ship Wt.
EZWSGRNM8PK	115V / 60Hz	8 GPH	3.8	260	76

**Based on 80°F inlet water & 90°F ambient air temp for 50°F chilled drinking water.



CONSTRUCTION

- Stainless steel bottle filler construction with ABS plastic alcove
- Includes stainless steel louvered ventilating grille
- Furnished with MFWS100 wall mounting box constructed of galvanized steel. Mounting can be ordered separately for pre-install.

Warranty: 5 year limited warranty on the unit's refrigeration system. Electrical components and water system are warranted for 12 months from date of installation or 18 months from factory shipment, whichever date falls first.

CERTIFICATIONS / STANDARDS

- ADA Compliant
- UL399 and CAN/CSA 22.2 No. 120 Certified (Only 115V models are certified)
- ANSI/NSF 61 and 372 Certified
- GreenSpec[®] Listed



This specification describes an Elkay product with design, quality and functional benefits to the user. When making a comparison of other producer's offerings, be certain these features are not overlooked.

EZH20[®] In-Wall Bottle Filling Station (for use with SwirFlo[®] EDFPBM) with High-efficiency ECH8GRN Chiller Model EZWSGRNM8PK

ELKAY[®]
ROUGH-IN

Job Name: _____
 Date: _____ Qty: _____
 Contact Info (Name, Phone, Email): _____

 Approval: _____

IMPORTANT:
DOUBLE STUD OR 3 INCHES (76 mm)
BETWEEN MOUNTING FRAMES
IF PLACED NEXT TO ANOTHER
BOTTLE FILLER, FOUNTAIN OR WALL

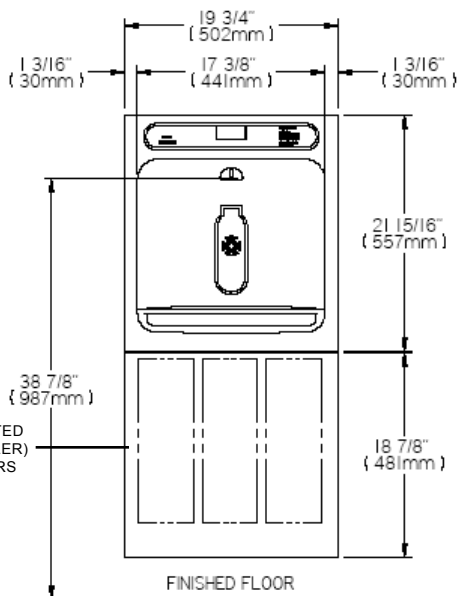
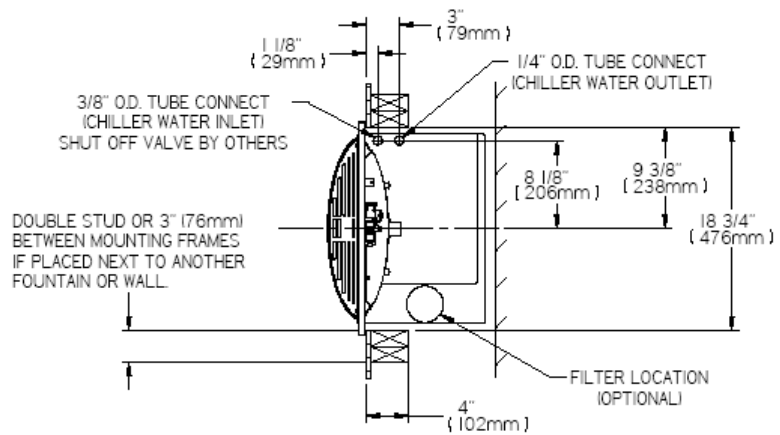
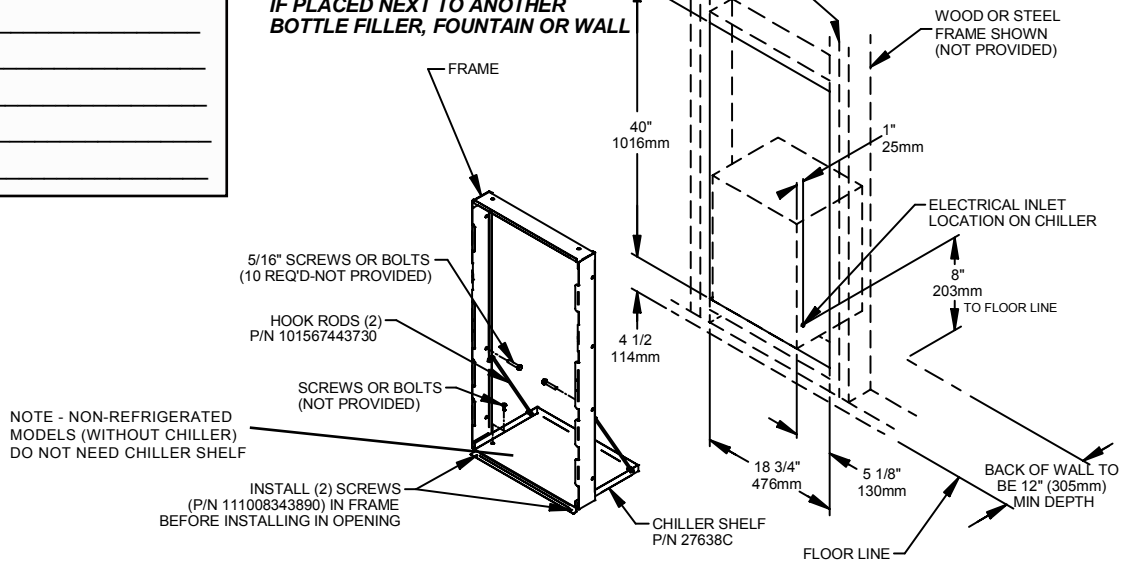

NOTE - NON-REFRIGERATED MODELS (WITHOUT CHILLER) DO NOT INCLUDE LOUVERS

